

Hillmar

Hillmar Industries Ltd.

7371 Vantage Way
Delta, BC V4G 1C9
P:604 946-7115 F:604 946-0329
info@hillmar.com www.hillmar.com

BRAKE LININGS
BLKSM-TDB-MD28-MD517
BRAKE LINING KIT

BO KIT

Company / Project Reference:

Page: 1 OF 1

Job Number:

Part ID: 180-080-68641PT Rev.: C

Document Package No.: Rev.:

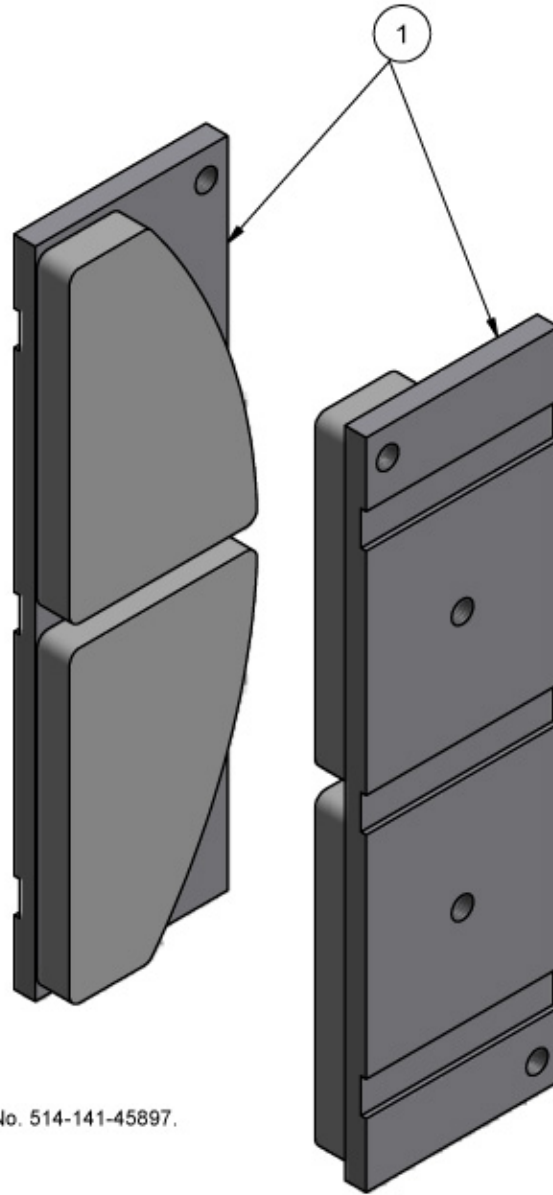
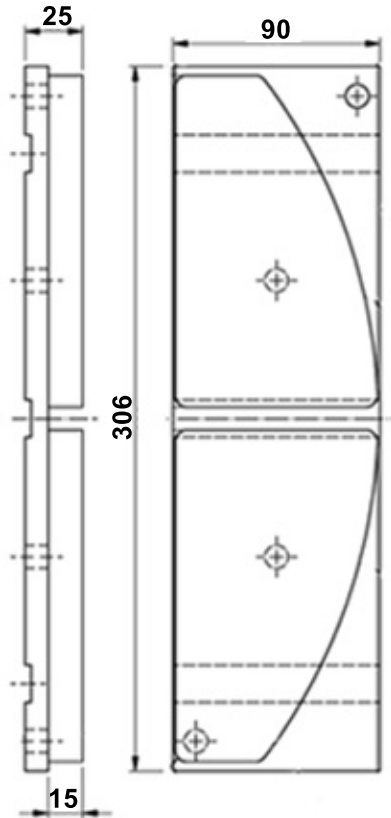

CERTIFIED FOR MANUFACTURE
DESTROY ALL OTHER DRAWINGS
GORAN BY
02 NOV 2011 DATE

NOTES:

1. REFER TO PACKAGING PROCEDURES DOCUMENT No. 514-141-45897.

QTY	SYSTEMS
-	SYSTEM AS SPECIFIED BELOW

BILL OF MATERIAL

ITEM	QTY	PART ID	REV.	22C-PRODUCT DESCRIPTION	30C-PRODUCT SPECIFICATION	30C-PART DESCRIPTION	10C-PROCESS/M	10C-ASSEMBLY
1	2	180-080-68641PT	C	BRAKE LININGS	BLSM-TDB-M28-MD28-MD517	BRAKE LINING W/ BKG PLT	BONDING	BO PART

Tolerance Unless Otherwise Specified: ISO 2768 - m		Material Spec. Sheet No.:	Process 1 No.:	Process 1:	Weight: 4.8 kg
Tolerance Spec. Sheet No.:		Material Description:	Process 2 No.:	Process 2:	Drawn By: GDJ
540-401-56438		Imperial Crossover:	Process 3 No.:	Process 3:	Date: 02NOV11
Projection					Approved By: Date:

C	GDJ	ITEM #1 CHANGED TO REV "C"	02NOV11				
B	GDJ	CHANGED ITEM #3, ITEM #1 CHANGED TO REV B	22APR10				

Rev.	Apr. by	REVISIONS	Date	Rev.	Apr. by	REVISIONS	Date
------	---------	-----------	------	------	---------	-----------	------