

Hillmar

Hillmar Industries Ltd.

7371 Vantage Way
Delta, BC V4G 1C9
P:604 946-7115 F:604 946-0329
info@hillmar.com www.hillmar.com

POWER CABLE REELS ME-25 MAGNET COUPLING TECHNICAL DATA SHEET

Sheet Number:

Job Number:

Form Number:
658-221-36807

Rev:

Company / Project Reference:

Date:
12/10/05

Page:
5 of 6

Document Package No.:
658-221-45461

Rev:
D

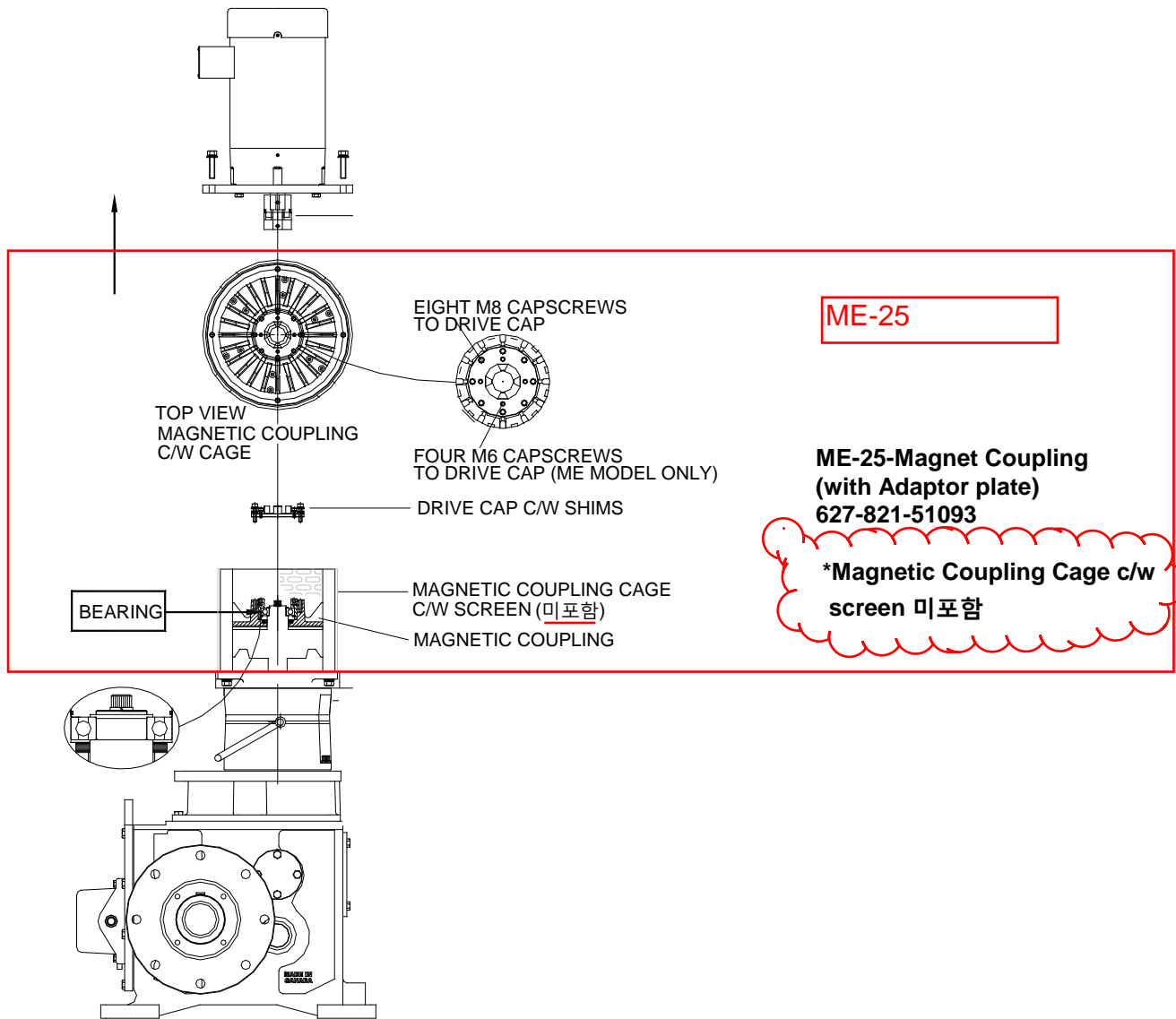

Model : ME-25

C	TM	UPDATED GEARBOX LUBE PROCEDURE	18/09/09				
B	ATM	UPDATED MAG CPLG LUBE PROCEDURE	06/07/09				
A	RCN	UPDATE FORMAT	08/22/06	D	ATM	GREASE SPEC SHEETS ADDED	27/01/09
Rev.	Apr. By	R E V I S I O N S	Date	Rev.	Apr. By	R E V I S I O N S	Date

Storm Brakes • Thruster Disc Brakes • Thrusters • Industrial Disc Brakes • Hydraulic Power Units • Cable Reels