

Hillmar

Hillmar Industries Ltd.

7371 Vantage Way
Delta, BC V4G 1C9
P:604 946-7115 F:604 946-0329
info@hillmar.com www.hillmar.com

BRAKE LININGS BLKSM-TDB-MD23-MD517 BRAKE LINING KIT

BO KIT

Company / Project Reference:

Page: 1 OF 1

Job Number:

Part ID:
180-080-56053PT

Rev.:

Document Package No.:

Rev.:

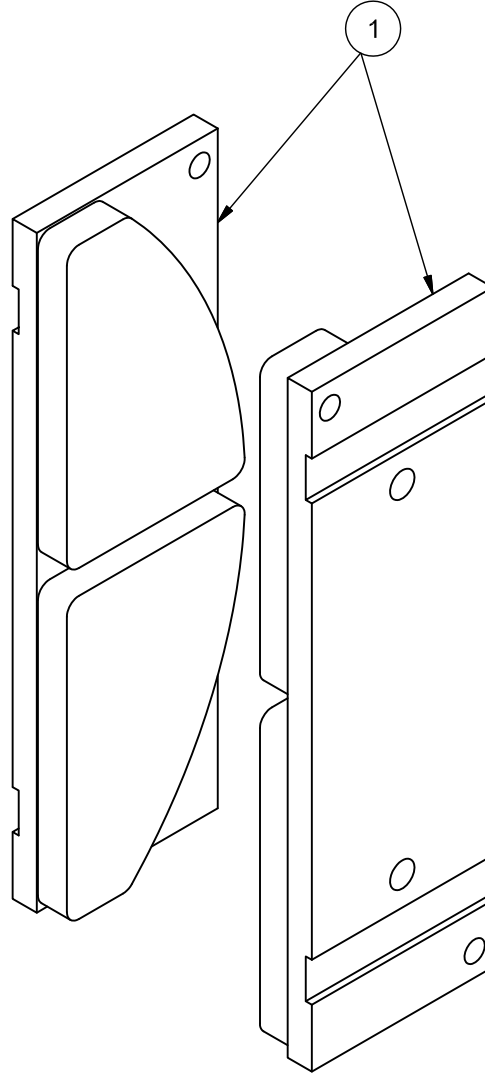
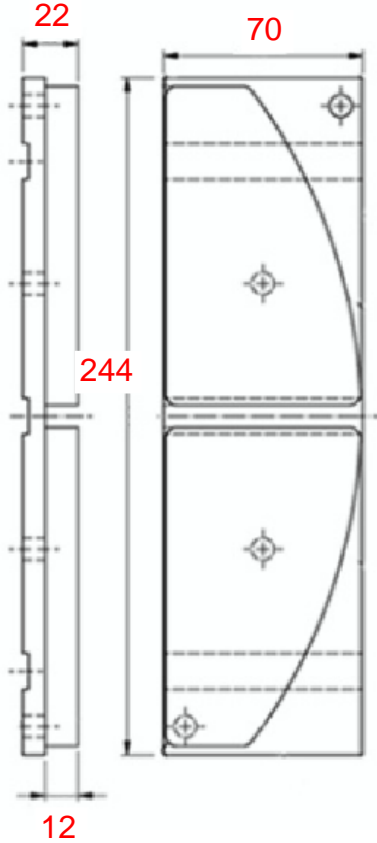

CERTIFIED FOR MANUFACTURE
DESTROY ALL OTHER DRAWINGS

BY BORISLAW
DATE 23 JUL 2015

QTY	SYSTEMS
-	SYSTEM AS SPECIFIED BELOW

NOTES:

1. REFER TO PACKAGING PROCEDURES DOCUMENT No. 514-141-45897.

BILL OF MATERIAL

ITEM	QTY	PART ID	REV.	22C-PRODUCT DESCRIPTION	30C-PRODUCT SPECIFICATION	30C-PART DESCRIPTION	10C-PROCESS/M	10C-ASSEMBLY
1	2	180-080-56052PT	C	BRAKE LININGS	BLSM-TDB-M23-MD23-MD517	BRAKE LINING W/ BKG PLT	BONDING	BO PART

Tolerance Unless Otherwise Specified: ISO 2768 -m		Material Spec. Sheet No.:	Process 1 No.:	Process 1:	Weight: 3.4kg	
Tolerance Spec. Sheet No.: 540-401-56438		Material Description:	Process 2 No.:	Process 2:	Drawn By:	Date:
Projection		Imperial Crossover:	Process 3 No.:	Process 3:	Approved By:	Date:

Rev.	Apr. by	REVISIONS	Date	Rev.	Apr. by	REVISIONS	Date
A	BOJ	UPDATED B.O.M.	23JUL15				

INVENTOR DRAWING