

CAD Drawing

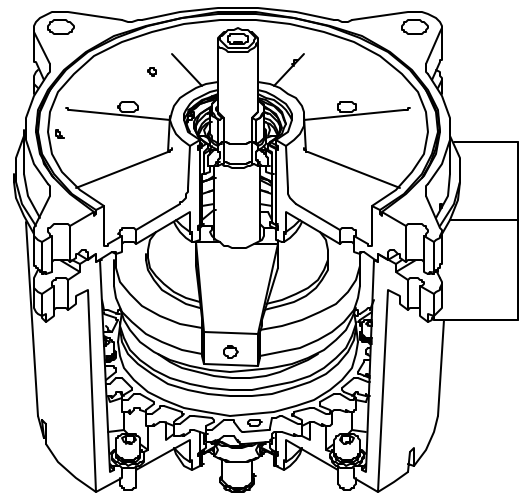
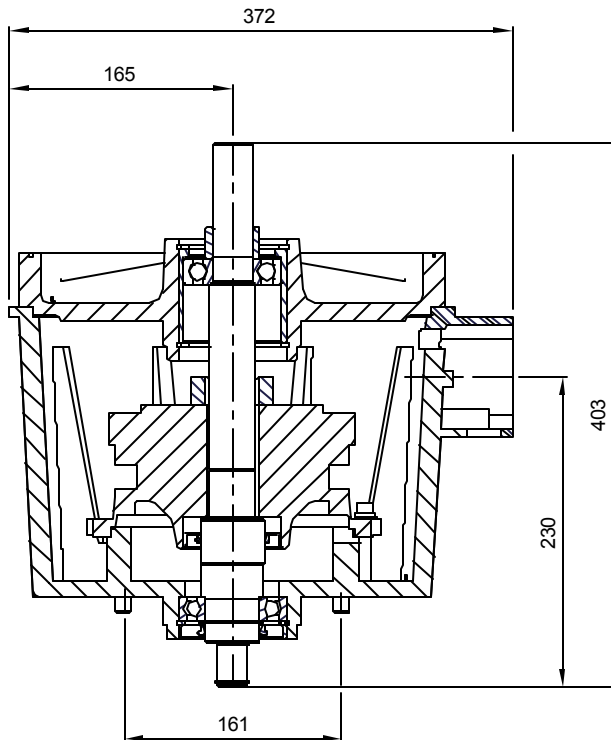

BRAKE				ELECTRICAL		AIR GAP		BRAKE TORQUE SETTINGS			
TYPE	MODEL	TORQUE [Nm]	SHAFT DIA [mm]	POWER [V-Ph-Hz]	RECTIFIER TYPE	MINIMUM	MAXIMUM	TYPE AND NUM. OF SPRINGS		SPRING PART NUMBER	
								STANDARD	RED	STANDARD	RED
ELECTRO MAGNETIC	BMG-8	30	22.2	440 / 3 / 60	BGE1.5	0.3	1.2	2	2	135 616 X	135 570 8

* NOTE:
POWER (VOLTAGE) AND RECTIFIER TYPE ARE JOB SPECIFIC.

ALL TECHNICAL DATA IS SUBJECT TO CHANGE WITHOUT NOTICE
Hillmar works have a fully registered ISO 9001 quality assurance programme (QCB #80088002).

Rev.	Rev. By	R E V I S I O N S			Date	Rev.	Rev. By	R E V I S I O N S			Date

Storm Brakes • Thruster Disc Brakes • Thruster • Industrial Disc Brakes • Hydraulic Power Units • Cable Reels