

CAD Drawing

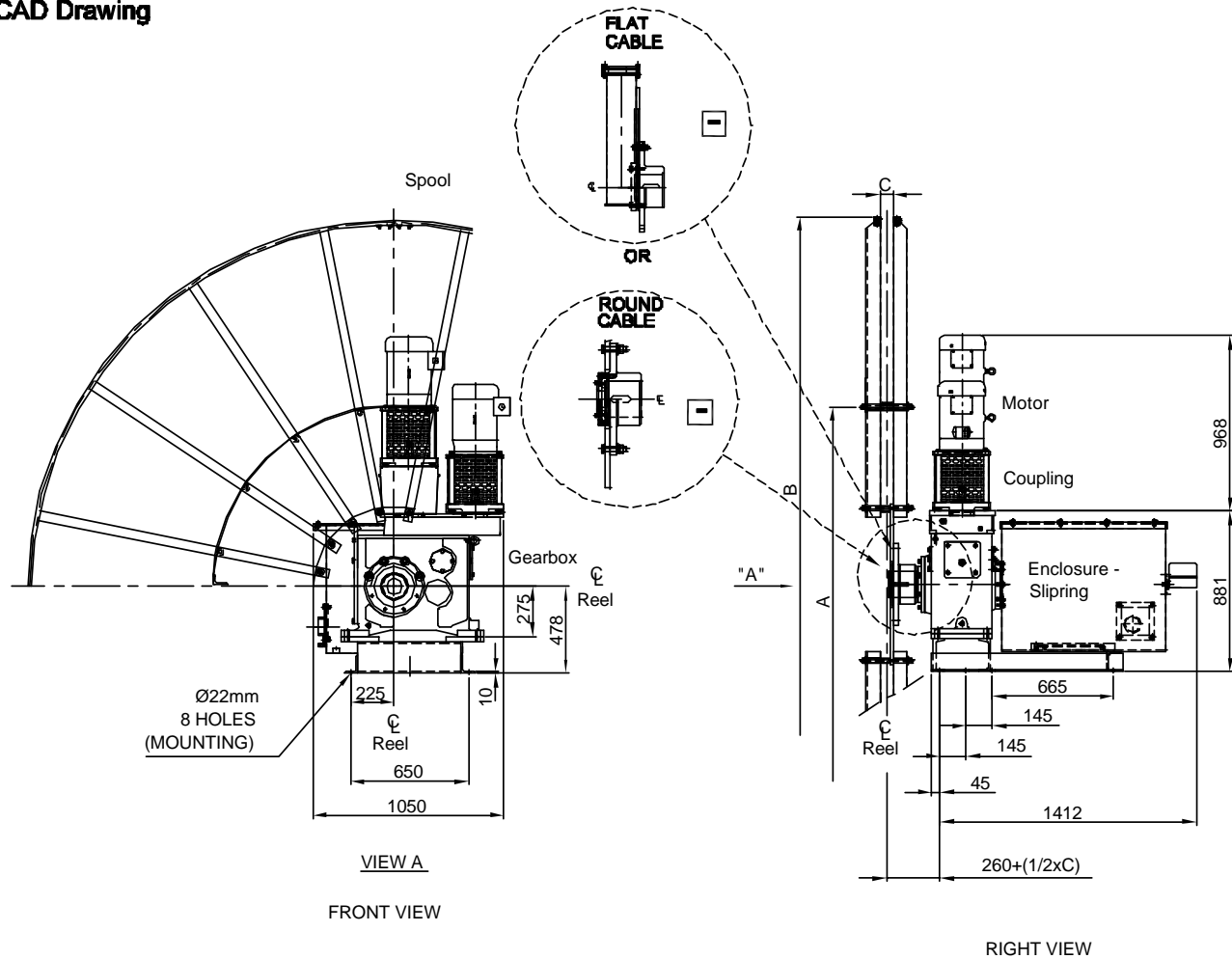

CABLE ENTRY DETAILS (See Specification Sheet)
 ROUND CABLE SPOOL DIMENSIONS A,B,C and D (See Specification Sheet)
 FLAT CABLE SPOOL DIMENSIONS A,B,C and D (See Specification Sheet)

N° OF UNITS	CR SERIES	GEARBOX	RATIO	ENCLOSURE	SLIPRING	COUPLING	VOLTAGE		BRAKE	CABLE TYPE	ROTARY SWITCH	DRIVE WT (kg) EXCLUD. SPOOL
							MOTOR POWER	CONTROL				
-	CRP	GBM-50	-	ENS-10	10KV	ME-25	- 3 -	- 1 -	-	-	-	1,170

Gearbox	Ratio
GBM-50	102
GBM-50	151
GBM-50	214

Brake type
EM-BMG-XXX
TRB-XXX

Cable type
Round cable RC
Flat cable FC

Rotary switch

* SIZE CONTRACT SPECIFIC SHOWN IN TCD

N. T. S.

** ALL TECHNICAL DATA IS SUBJECT TO CHANGE WITHOUT NOTICE **
 Hillmar works have a fully registered ISO 9001:2000 quality assurance programme (QCS #01-1826).