

Hillmar

Hillmar Industries Ltd.

CABLE REEL LUBRICATION OPERATION AND MAINTENANCE MANUAL

Company / Project Reference:

Date: DD MM YY

12 10 05

Sheet Number:

Job Number:

625-208-02054JB

Form Number:

658-082-36807

Rev:

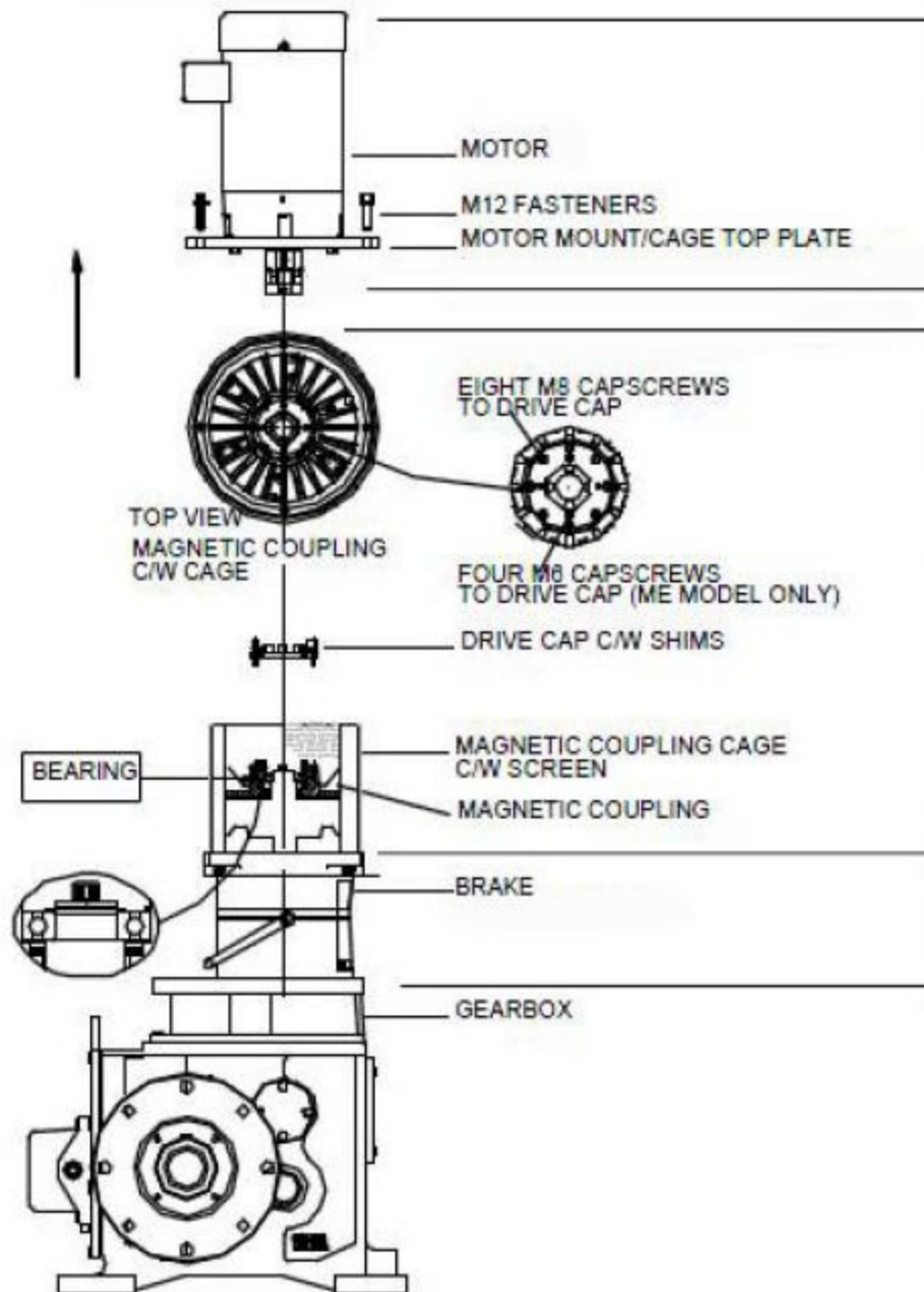

EMN-075-213-TC-NF-460-3-60
MOTOR (with Jaw Coupling & Insert)
164-076-54452

ME-25- Magnet Coupling
(with Adaptor plate)
627-821-51093

EM-BMG-8-078-30 Brake
629-853-38575

Full Set Model

EMN-075-213-TC-NF-460-3-60 / ME-25 / EM-BMG-8-078-30

| Rev. | Apr. By | R E V I S I O N S | Date | Rev. | Apr. By | R E V I S I O N S | Date |
|------|---------|-------------------|------|------|---------|-------------------|------|
| | | | | | | | |
| | | | | | | | |

Storm Brakes • Thruster Disc Brakes • Thrusters • Industrial Disc Brakes • Hydraulic Power Units • Cable Reels

7371 Vantage Way
Delta, B.C., Canada V4G 1C9

Tel: +1-604-946-7115
Fax: +1-604-946-0329

info@hillmar.com
www.hillmar.com